

UFO P2N Paver

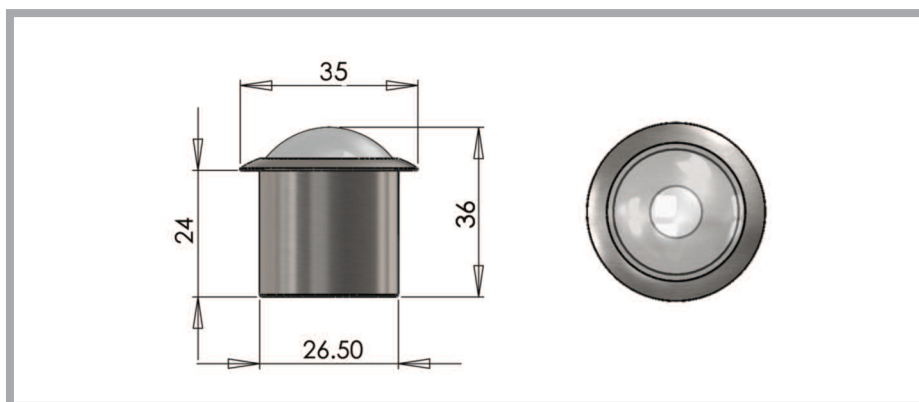

A round paver with a domed lens manufactured from stainless steel with either clear or frosted glass. The use of a domed lens means that the light output from this paver is focusable.

The clear glass gives greater light output and also allows the light to travel further, while the frosted glass creates more of a marker light effect.

Description	
Glass	Ø26mm clear or frosted glass
Beam angle	60°
Material	Stainless steel
Colours available	Natural
Flange size	35 mm
Weight	80 g
Mounting hole size	27 mm
Ferrule size	M10 or 8 mm smooth
Min. fibre size	2 mm
Max. fibre size	8 mm

Part numbers for ordering: P2NC (clear glass) P2NF (frosted glass)

Our paver fittings are suitable for use in a variety of different applications and are the ideal solution to floor level lighting both indoors and outside.

Uses include:

- Marker lighting for pathways and entrances
- Wall washing, inside or out
- Uplighting columns or archways
- Mood lighting in any room in the house, including wet rooms and pool areas

Paver fittings can be installed in many surfaces including wooden floors, decking, paving, stair skirting and concrete.